

SMART Board™ Interactive Whiteboard

Specifications – Model 640

Physical Specifications

Size	Interactive Whiteboard	42" W × 32" H × 5 1/8" D (106.7 cm × 81.3 cm × 13.0 cm)
	Active Screen Area	38 3/8" W × 28 3/4" H (97.5 cm × 73.0 cm) 48" (121.9 cm) diagonal
	FS640 Floor Stand (with SB640 Installed)	42" W × 52 3/4" to 66 3/4" H × 40 1/4" D (106.7 cm × 134.0 cm to 169.6 cm × 102.2 cm)
Weight	Interactive Whiteboard	14 lb. 12 oz. (6.7 kg)
Shipping Size	Carton	49 3/8" W × 46 5/8" H × 5 1/2" D (125.4 cm × 118.4 cm × 14.0 cm)
Shipping Weight	Carton and Contents	26 lb. 8 oz. (12.0 kg)

All dimensions +/- 1/8" (3.2 mm). All weights +/- 2 lb. (0.9 kg).

Standard Features

Software	SMART Board software, including Notebook™ software. Free software upgrades are available at www.smarttech.com/support/software/index.asp .
Pen Tray	Optical sensors in the pen tray detect when a pen or eraser is lifted from the tray. LEDs show the active tool.
Pens and Eraser	Black, blue, red and green Whisper-tip™ pens and a rectangular eraser
Resolution	Touch resolution is approximately 4000 × 4000
Screen Surface	The hard-coated polyester surface is tear proof, optimized for projection, compatible with dry-erase markers and is easily cleaned with whiteboard cleaner
Digitizing Technology	Analog resistive
Frame Finish	Two-tone gray (approximates Pantone® gray 18-0601) and Ultrasonic Chrome (approximates metallic Pantone 877c)
Wall-Mount Bracket	Supports the interactive whiteboard when mounted to a wall
Computer Connection	16' (4.9 m) USB 2.0 cable
Power Requirements	Power is obtained from the computer directly through the USB cable for both Windows® and Macintosh computers. Power consumption is less than 1.5 watts (300 mA at 5V).
Certifications	CSA (Canada/U.S.), CE, CB (TUV)
Warranty	Five-year limited equipment warranty upon registration

NOTE: A digital projector is *not* included with these models of SMART Board interactive whiteboards. To take advantage of all interactive features, you must integrate a digital projector.

Computer Requirements

Windows Operating Systems	Pentium® 150 MHz processor (450 MHz or faster recommended) 128 MB of RAM (256 MB recommended) Available powered USB or serial port Approximately 160 MB of free hard disk space for full installation Windows NT® 4.0 (SP6), Windows 98 operating system or later Microsoft Internet Explorer 6.0 or later Macromedia® Flash® player version 7.0.19 or later (recommended)
Requirements for SMART Video Player	Pentium 450 MHz processor (700 MHz or faster recommended) Windows 98 operating system or later. Does not run on the Windows NT operating system. Microsoft DirectX® 8.1 End-User Runtime or later
Macintosh Computers	400 MHz processor (800 MHz or faster recommended) 128 MB of RAM (256 MB recommended) Mac OS X version 10.1.5 or later (with Java™ version 1.3.1 update 1 or later) 50 MB of free hard disk space for minimum installation, 115 MB for full installation with Gallery collections Available powered USB port

NOTE: SMART Board software is not compatible with versions 10.3.0, 10.3.1 or 10.3.2 of the Mac OS X operating system. To use the handwriting recognition feature, you must have Mac OS X version 10.3.3 or later. To use the SMART Airliner™, you must have Mac OS X version 10.3 or later.

Storage and Operating Specifications

Storage	-40°F to 120°F (-40°C to 50°C) with up to 95% humidity non-condensing
Operation	41°F to 95°F (5°C to 35°C) with up to 80% humidity non-condensing

SMART Order Number

SB640	48" (121.9 cm) diagonal SMART Board Interactive Whiteboard
-------	--

Optional Accessories

CB6	Firm-sided carrying bag for the SMART Board 640 interactive whiteboard
CBJ-640	Padded carrying bag for the SMART Board 640 interactive whiteboard and the TS640 table stand
FS640	Mobile floor stand with 4" (10.2 cm) lockable casters and flip-up anti-tip feet
HSCJ-640	Hard shipping case for the SMART Board 640 interactive whiteboard and the TS640 table stand
RS232-NA	RS232 to USB conversion module that allows a serial connection to the interactive whiteboard as an alternative to USB (Canada and U.S.)
RS232-UK	RS232 to USB conversion module that allows a serial connection to the interactive whiteboard as an alternative to USB (United Kingdom)
SBA-NA	Two 15 watt speakers to mount to the interactive whiteboard or wall (Canada and U.S.)
SBA-UK	Two 15 watt speakers to mount to the interactive whiteboard or wall (United Kingdom)
SYSON6-NA	SystemOn expansion module wakes up the computer and turns on the projector with one button press (Canada and U.S.)
SYSON6-UK	SystemOn expansion module wakes up the computer and turns on the projector with one button press (United Kingdom)
TS640	Table stand installs quickly to allow the SMART Board 640 interactive whiteboard to be used on a table
USB-XT	16 1/2' (5.0 m) USB extension cable
WC6-NA	Wireless Bluetooth™ connection between the SMART Board interactive whiteboard and the computer (Canada and U.S.)
WC6-UK	Wireless Bluetooth connection between the SMART Board interactive whiteboard and the computer (United Kingdom)
20-00653	Set of four Whisper-tip styluses (black, red, blue and green) and rectangular eraser
STYF-005-00	Set of four Whisper-tip styluses (black, red, blue and green)
93-00507-00	16 1/2' (5.0 m) USB-A to USB-B cable

SMART Technologies Inc.
1207 – 11 Avenue SW, Suite 300
Calgary, AB T3C 0M5
CANADA
Phone +1.403.245.0333
Toll Free 1.888.42.SMART (Canada/U.S.)
info@smarttech.com www.smarttech.com

SMART
Technologies

SMART Board™ Interactive Whiteboard

Specifications – Model 640

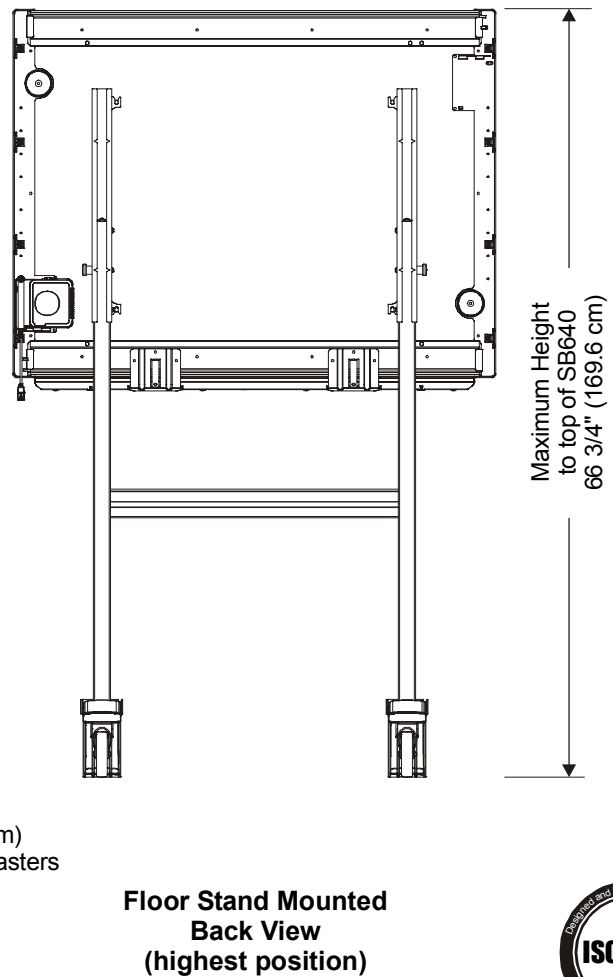
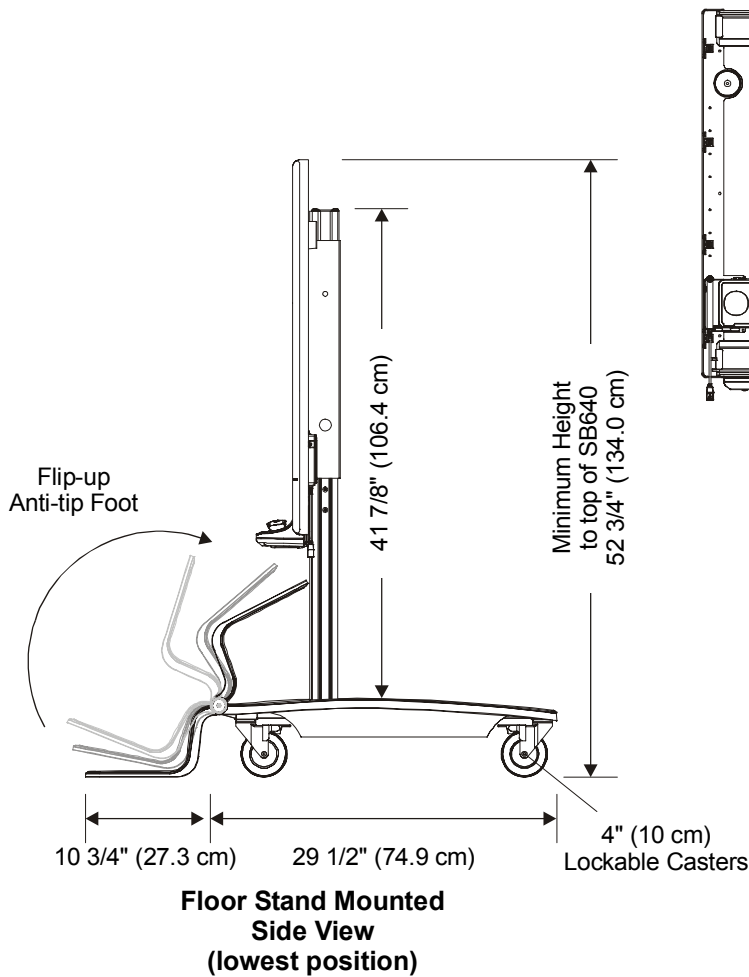
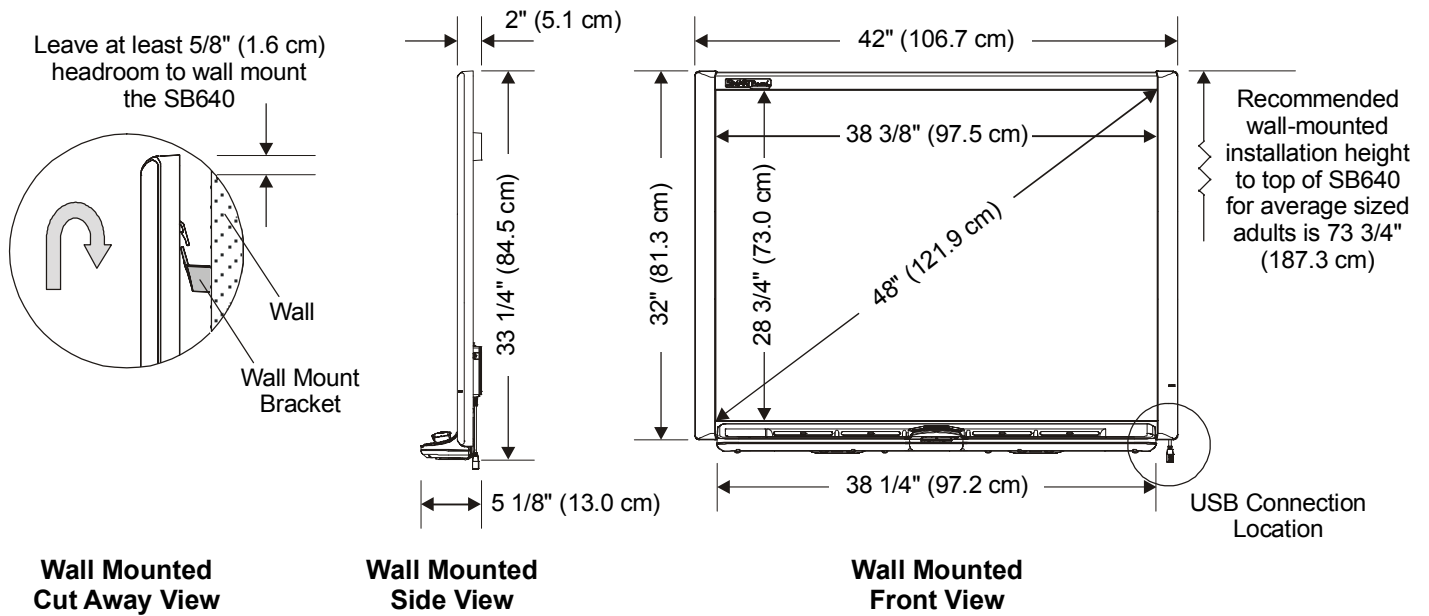

All dimensions +/- 1/8" (0.3 cm)

