

PLEASE THINK BEFORE YOU PRINT

Specifications

Fixed Unit Wall Mount 600

Model FUWM-600

Physical Specifications

Size	75 1/4" W × 65 1/2" H × 4 1/2" D (191.1 cm × 166.4 cm × 11.4 cm)
Weight	39 lb. (17.7 kg)
Shipping Size	61 1/4" W × 17 3/4" H × 9" D (155.6 cm × 45.1 cm × 22.9 cm)
Shipping Weight	54 lb. (24.5 kg)

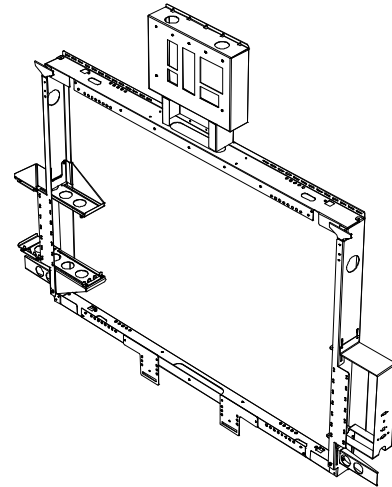

All dimensions +/- 1/8" (0.3 cm). All weights +/- 2 lb. (0.9 kg)

WARNING

Check your local building codes to ensure that your wall can support the combined weight.

Standard Features

Mounting Hardware	Hardware is included for mounting the fixed unit wall mount on solid walls made of brick, cinder block or concrete, as well as on metal stud and wood framed walls.
Hardware Features	<p>You can install your computer or SMART Hub appliance on the left or right side of the fixed unit wall mount behind the SMART Board™ interactive whiteboard.</p> <p>You can install your computer between two adjustable computer brackets on the side of the fixed unit wall mount. The adjustable computer brackets enable you to connect any computer that's 4 1/8" W × 13 7/8" H × 14 7/8" D (10.5 cm × 35.2 cm × 37.8 cm) or smaller.</p> <p>You can mount a SMART Hub appliance on the opposite side of the fixed unit wall mount.</p>
Casing	Dark gray powder-coated steel sheet

Extraordinary made simple™

SMART™

Environmental Compliance	China EIP, EU RoHS, EU WEEE and Packaging
Regulatory Certification	CE, CSA/UL
Warranty	Two-year limited equipment warranty
Health and Safety	Two people are required to safely assemble the fixed unit wall mount and to install the interactive whiteboard system.

Configurations for SMART Board Interactive Whiteboard Systems for Business

You can use the fixed unit wall mount with the following product configurations.

Premium SMART Board 685ix Interactive Whiteboard System (Computer-Based)	<p>This system enables you to use your computer with a SMART Board 685 interactive whiteboard, UX60 projector, Extended Control Panel (ECP), fixed unit wall mount and USB audio system. SMART Meeting Pro™ Premium software is included.</p> <p>For a complete list of system requirements, see the specifications documents for the following:</p> <ul style="list-style-type: none"> • SMART Board 685ix interactive whiteboard system • USB audio system for SMART Board 600 series interactive whiteboards
Premium SMART Board 685ix Interactive Whiteboard System (Appliance-Based)	<p>This system combines a SMART Hub SE240 with a SMART Board 685 interactive whiteboard, UX60 projector, control module, fixed unit wall mount and USB audio system.</p> <p>For a complete list of system requirements, see the specifications documents for the following:</p> <ul style="list-style-type: none"> • SMART Board 685ix interactive whiteboard system • SMART Hub SE240 • USB audio system for SMART Board 600 series interactive whiteboards
SMART Board 685ix Interactive Whiteboard System (Appliance-Based)	<p>This system combines a SMART Hub VE220 with a SMART Board 685 interactive whiteboard, UX60 projector, control module, fixed unit wall mount and USB audio system.</p> <p>For a complete list of system requirements, see the specifications documents for the following:</p> <ul style="list-style-type: none"> • SMART Board 685ix interactive whiteboard system • SMART Hub VE220 • USB audio system for SMART Board 600 series interactive whiteboards

SMART Board Interactive Whiteboard Systems for Business Upgrade Kits**Business Upgrade Kit
(Premium
Computer-Based)**

This system enables you to use your computer, your SMART Board 685 or 680 interactive whiteboard and your UX60, SMART UF55w or SMART UF55 projector, with a fixed unit wall mount and a USB audio system. SMART Meeting Pro Premium software is included.

For a complete list of system requirements, see the specifications documents for the following:

- [SMART Board 685ix interactive whiteboard system](#)
- [SMART Board 685i3 interactive whiteboard system](#)
- [SMART Board 680i3 interactive whiteboard system](#)
- [SMART Board 685 interactive whiteboard system](#)
- [SMART Board 680 interactive whiteboard system](#)
- [USB audio system for SMART Board 600 series interactive whiteboards](#)

**Business Upgrade Kit
(Premium
Appliance-Based)**

This system enables you to use your SMART Board 685 or 680 interactive whiteboard and your UX60, SMART UF55w or SMART UF55 projector, with a SMART Hub SE240, control module, fixed unit wall mount and USB audio system.

For a complete list of system requirements, see the specifications documents for the following:

- [SMART Board 685ix interactive whiteboard system](#)
- [SMART Board 685i3 interactive whiteboard system](#)
- [SMART Board 680i3 interactive whiteboard system](#)
- [SMART Board 685 interactive whiteboard system](#)
- [SMART Board 680 interactive whiteboard system](#)
- [SMART Hub SE240](#)
- [USB audio system for SMART Board 600 series interactive whiteboards](#)

**Business Upgrade Kit
(Appliance-Based)**

This system enables you to use your SMART Board 685 or 680 interactive whiteboard and your UX60, SMART UF55w or SMART UF55 projector, with a SMART Hub VE220, control module, fixed unit wall mount and USB audio system.

For a complete list of system requirements, see the specifications documents for the following:

- [SMART Board 685ix interactive whiteboard system](#)
- [SMART Board 685i3 interactive whiteboard system](#)
- [SMART Board 680i3 interactive whiteboard system](#)
- [SMART Board 685 interactive whiteboard system](#)
- [SMART Board 680 interactive whiteboard system](#)
- [SMART Hub VE220](#)
- [USB audio system for SMART Board 600 series interactive whiteboards](#)

SMART Order Numbers

- SB685ix-MPP** Includes a SMART Board 685 interactive whiteboard, UX60 projector, ECP, fixed unit wall mount, USB audio system and SMART Meeting Pro Premium
- SB685ix-HSE** Includes a SMART Board 685 interactive whiteboard, UX60 projector, control module, fixed unit wall mount, USB audio system and SMART Hub SE240
- SB685ix-HVE** Includes a SMART Board 685 interactive whiteboard, UX60 projector, control module, fixed unit wall mount, USB audio system and SMART Hub VE220

SMART Board Interactive Whiteboard Systems for Business Upgrade Kits

- BK-MPP** Includes a fixed unit wall mount, USB audio system and SMART Meeting Pro Premium that you can use with your computer, SMART Board 685 or 680 interactive whiteboard, your UX60, SMART UF55w or SMART UF55 projector, and your ECP
- BK-HSE** Includes a fixed unit wall mount, USB audio system, control module and SMART Hub SE240 that you can use with your SMART Board 685 or 680 interactive whiteboard and UX60, SMART UF55w or SMART UF55 projector
- BK-HVE** Includes a fixed unit wall mount, USB audio system, control module and SMART Hub VE220 that you can use with your SMART Board 685 or 680 interactive whiteboard and UX60, SMART UF55w or SMART UF55 projector

Physical Dimensions

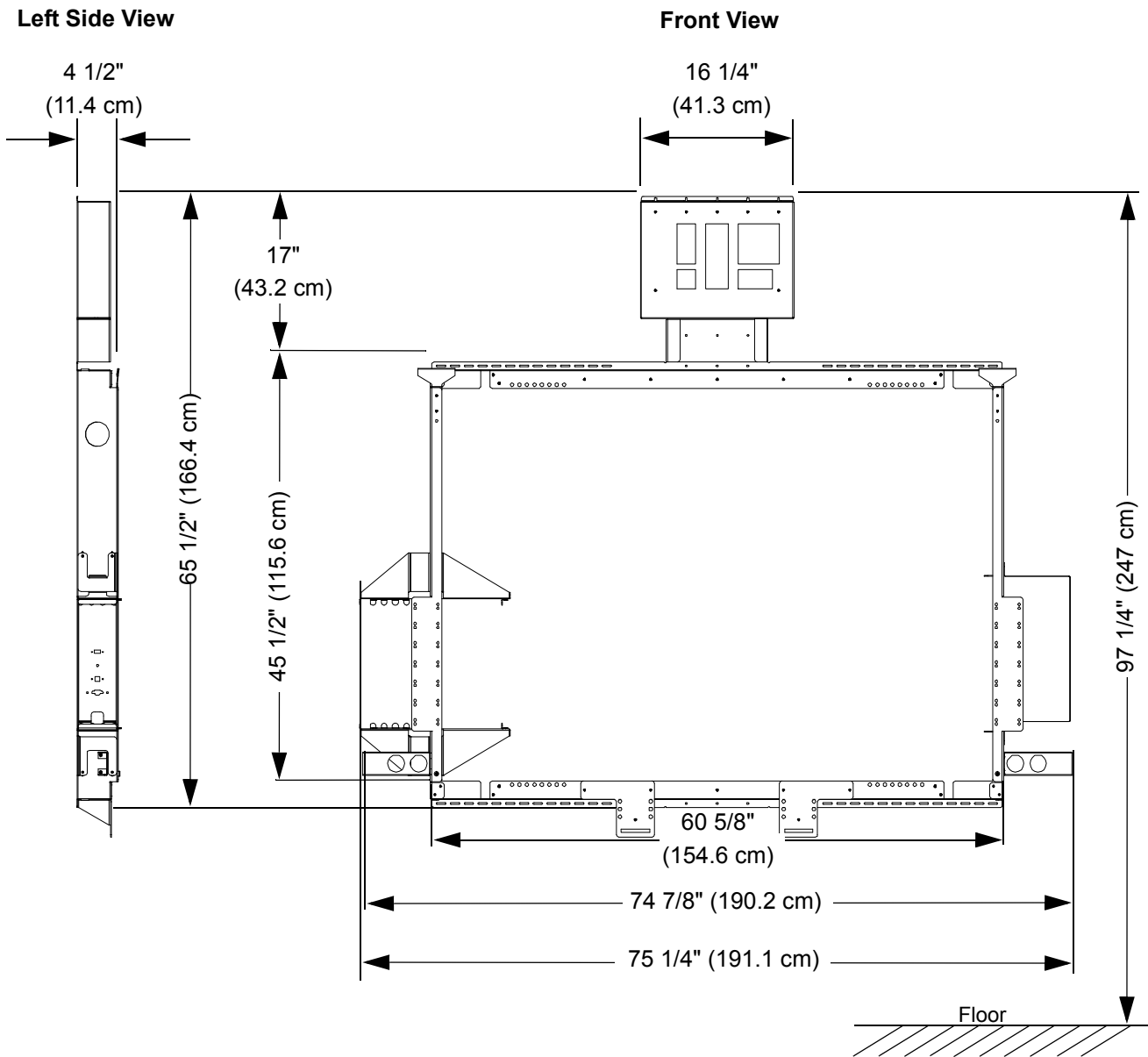

www.smarttech.com/support www.smarttech.com/contactsupport
 Support +1.403.228.5940 or Toll Free 1.866.518.6791 (U.S./Canada)



©2010 SMART Technologies ULC. All rights reserved. SMART Meeting Pro, SMART Board, the SMART logo and smarttech are trademarks or registered trademarks of SMART Technologies ULC in the U.S. and/or other countries. All third-party product and company names may be trademarks of their respective owners. Patents pending. Contents are subject to change without notice. 01/2010.