

Actalyst™ Interactive Digital Signage

Specifications – Models KPX350 for Select 50" Flat Panels

Physical Specifications

Size	31 1/4" W × 54 1/4" H × 2 3/8" D (79.4 cm × 137.7 cm × 6.0 cm)
Mounting Bracket Size	34 5/8" W × 6 1/2" H × 3 5/8" to 5 3/4" D (87.9 cm × 16.5 cm × 9.4 cm to 14.8 cm)
Weight	55 lb. (25.0 kg)
Shipping Size	
1 unit	59" W × 48" H × 14" D (149.9 cm × 121.9 cm × 35.6 cm)
3 units on pallet	60" W × 54" H × 43" D (152.4 cm × 137.2 cm × 109.2 cm)
Shipping Weight	
1 unit	85 lb. (38.6 kg)
3 units on pallet	275 lb. (125.0 kg)

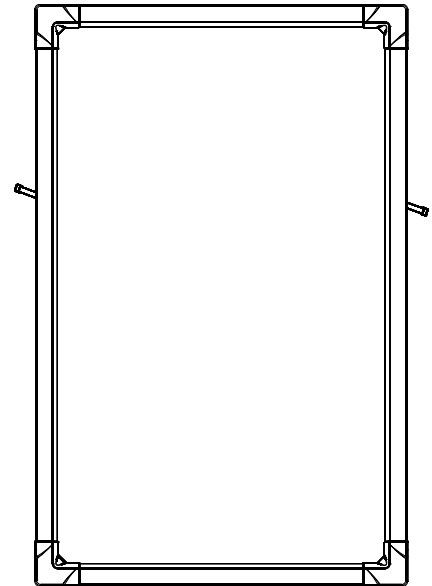

All dimensions +/- 1/8" (0.3 cm). All weights +/- 2 lb. (0.9 kg).

Standard Features

Software	Actalyst™ interactive overlay touch driver software. Upgrades are available at smarttech.com/software .
Controller	You can mount the controller on the back of the interactive overlay with two included thumbscrews. A modular cable connects the interactive overlay to the controller, and the controller connects to a computer with the included 21' 6" (6.5 m) USB/serial converter cable. The DB9 serial connector connects to the controller and the USB connector connects to an available USB receptacle on the computer.
Mounting Bracket	The mounting bracket has an adjustable depth feature to accommodate most 46" flat panels installed in a portrait orientation.
Front Surface Material	Hard-coated, anti-glare polyester that's designed for optimal light transmission. Chemical and scratch resistant.
Digitizing Technology	DViT™ (Digital Vision Touch) technology uses two digital cameras in the top two corners of the interactive overlay to track an object interacting with the display surface.
Power Requirements	Switching power supply, 100V–250V AC, 47 Hz–63 Hz, 12V DC 4.2A, 6' (1.8 m) power cord
Power Consumption	Power consumption is up to 40 W.
Compliance	CE, WEEE, RoHS (Europe), RoHS (China)
Warranty	Two-year limited equipment warranty
Installation Notes	You can install the interactive overlay on a flat panel that is securely mounted to a wall or floor stand. However, the wall mount or floor stand must be able to support a combined weight of 170 lb. (77.1 kg). Because of stability and mechanical fit issues, table stands are not recommended. You cannot attach speakers directly to the sides of a flat panel when an interactive overlay is installed. Do not install the Actalyst interactive overlay where it will be exposed to the weather or direct sunlight.

Computer Requirements

Windows® Computers	Pentium® II 450 MHz processor 128 MB of RAM (256 MB recommended) 60 MB of free hard disk space Windows 2000, Windows XP or Windows Vista™ operating system Internet Explorer® internet browser 6.0 or later
Mac Computers	700 MHz processor (1 GHz or faster recommended) 97 MB of RAM (256 MB recommended) 75 MB of free hard disk space Mac OS X version 10.4.x operating system software Safari application program version 1.3.2 or later SMART Board software version 9.7 supports both PowerPC® and Intel® processors (universal binary)
Linux® Computers	Pentium II 450 MHz processor 128 MB of RAM (256 MB recommended) 28 MB of free hard disk space Linux kernel version 2.6 or later X Window System™ version 11 release 6 (X11R6) or later (must support XRender, Xinerama™, XFixes, Xau and Xdmcp) glibc 2.3.3 (gcc 3.4.2) libstdc++6 GNOME™ 2.8.0+ or KDE® 3.3+ libraries (recommended) SUSE™ 10, Red Hat® Enterprise Linux 4 WS, Debian® 3.1 (Sarge), Ubuntu® 6.06 LTS or Fedora™ Core 3+

Storage and Operating Specifications

Storage	-40°F to 95°F (-40°C to 35°C) with up to 80% humidity non-condensing
Operation	41°F to 95°F (5°C to 35°C) with up to 80% humidity non-condensing

Dimensions

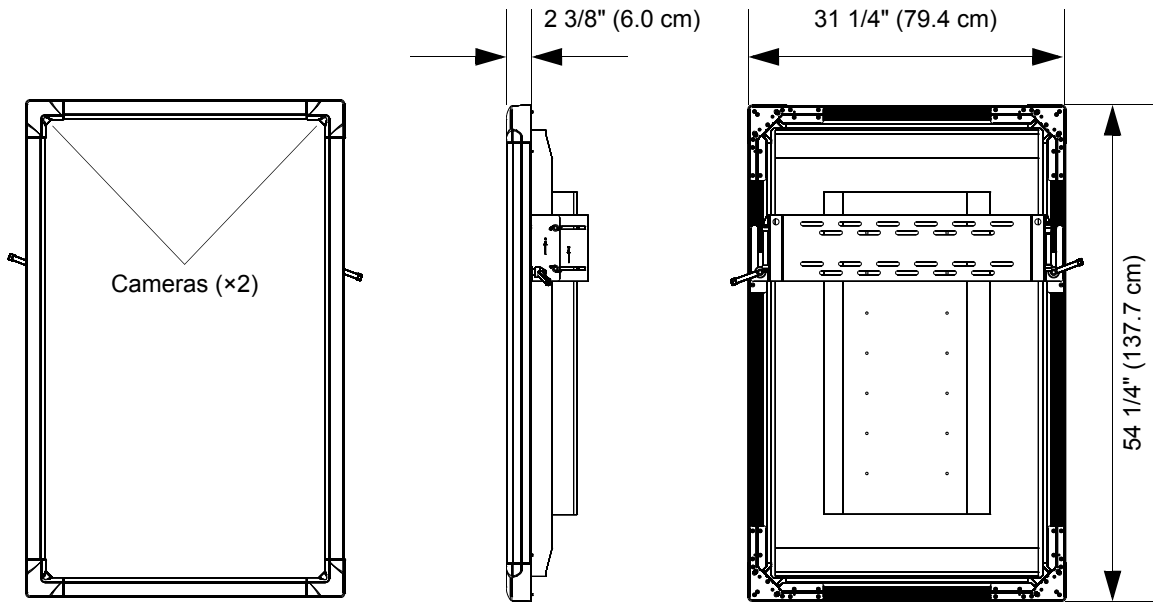

SMART Order Number

KPX350

Actalyst interactive overlay for select 50" flat panels in portrait orientation

SMART Technologies

3636 Research Road
Calgary, AB T2L 1Y1
CANADA



www.smarttech.com/support www.smarttech.com/contactsupport
Support +1.403.228-5940 or Toll Free 1.866.518.6791 (Canada/U.S.)