

SMART electric height-adjustable mobile stand wheelbase replacement

FSE-410 and FSE-400

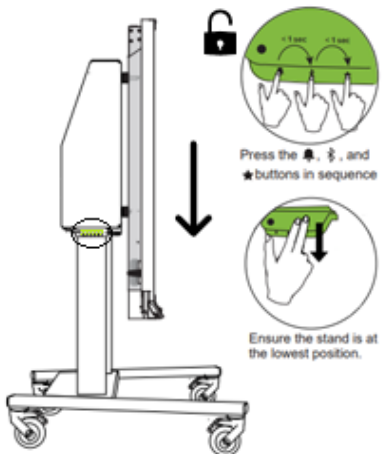
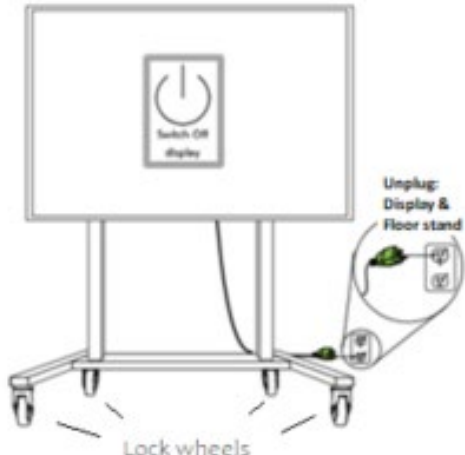
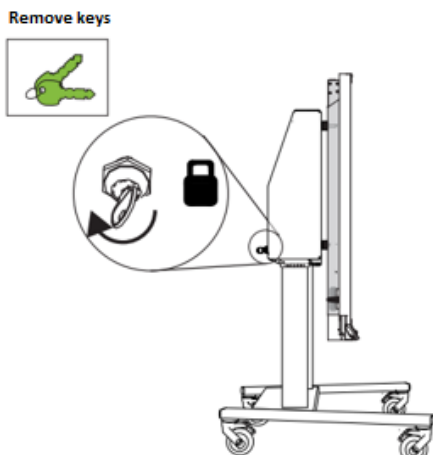
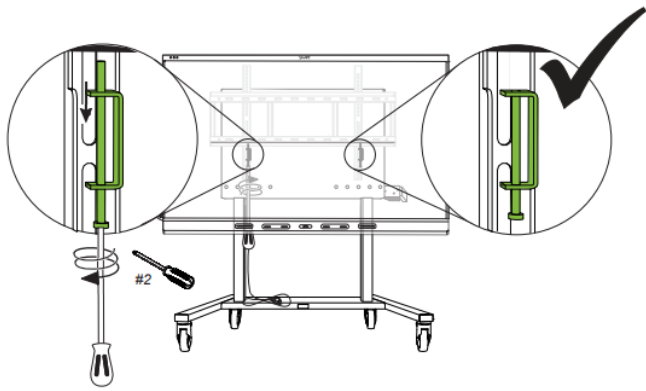

Before you assemble your stand, make sure the replacement wheelbase endcaps are securely in place and without any defects. If attention is needed, refer to the bottom of the work instructions.

1. Lower floor stand	2. Power off & unplug
 <p>Note: No need to unlock FSE-400</p>	
3. Lock cabinet & remove keys	4. Loosen display locks
	

SMART electric height-adjustable mobile stand wheelbase replacement

FSE-410 and FSE-400

5. Unmount the display

Note: Ensure that the SMART display is positioned securely on the floor in an upright position, with proper back support.

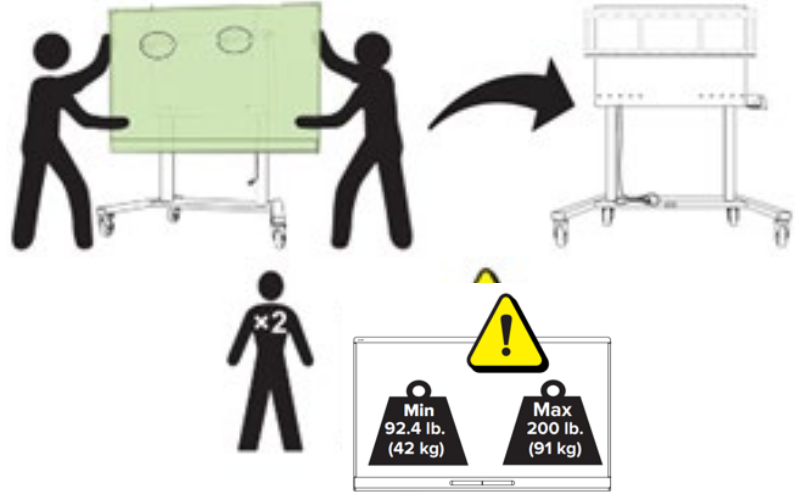

6. Lay the floor stand on its back

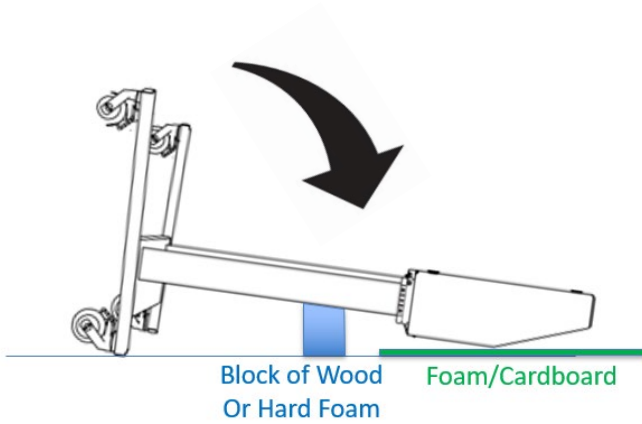

Use support and protection when laying the unit on its side

7. Remove the wheelbase

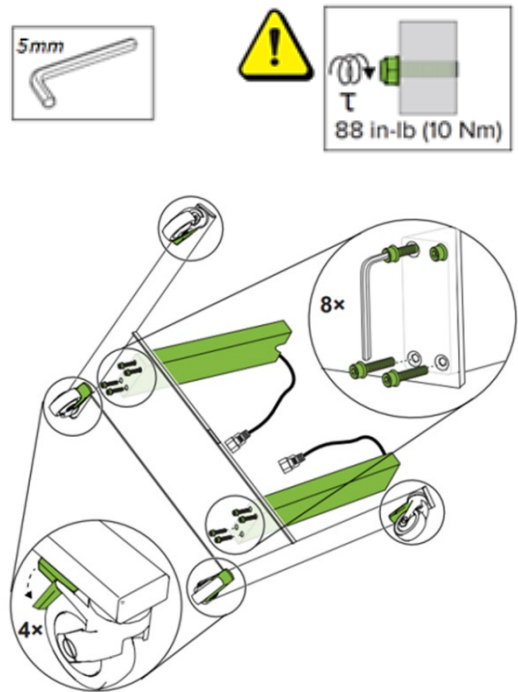

SMART electric height-adjustable mobile stand wheelbase replacement

FSE-410 and FSE-400

8. Record the floor stand's Serial Number, as well as the batch numbers of the current wheelbase and the replacement wheelbase in the supplied data sheet (see end of this document). Verify that the batch number of the current wheelbase is included in the provided list before proceeding with the replacement. If not, locate the defective wheelbase elsewhere and proceed with the replacement as necessary.

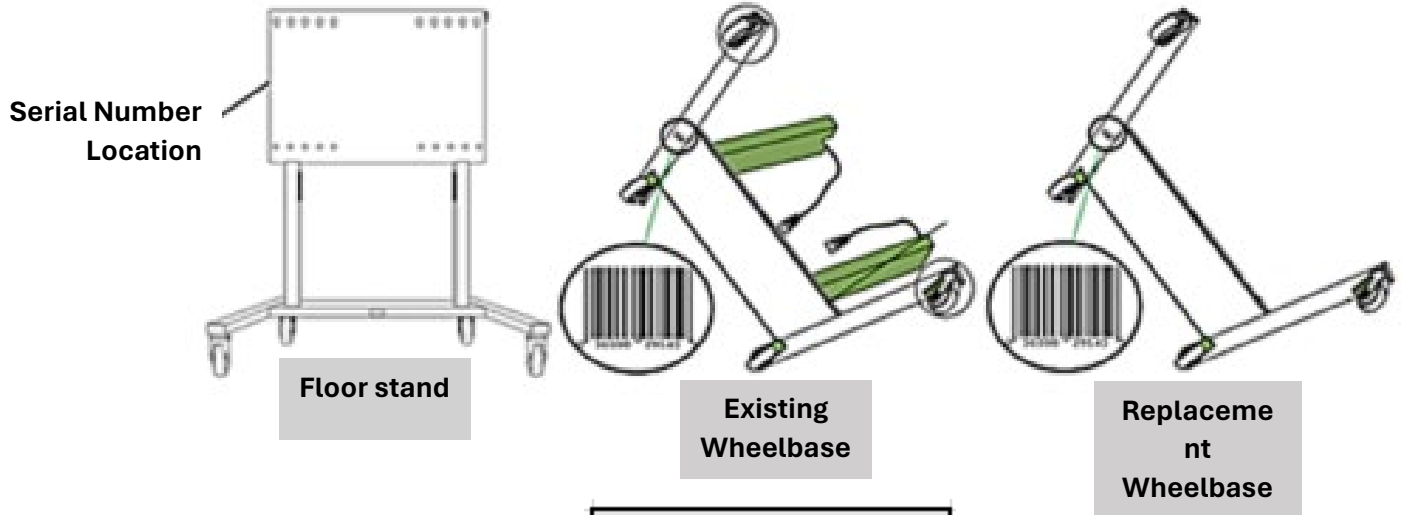

Defective Wheelbase Batch
2023034300005
2023050300003
2023050400000
2023054500003
2023066100000
2023071900008
2023080700002

SMART electric height-adjustable mobile stand wheelbase replacement

FSE-410 and FSE-400

9. Remove casters from old wheelbase and mount on new wheelbase

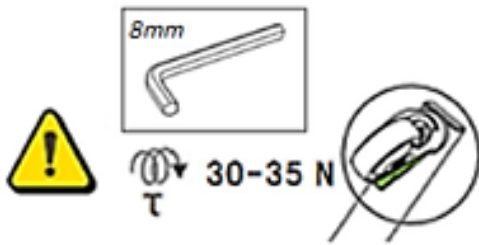

10. Install the new wheelbase

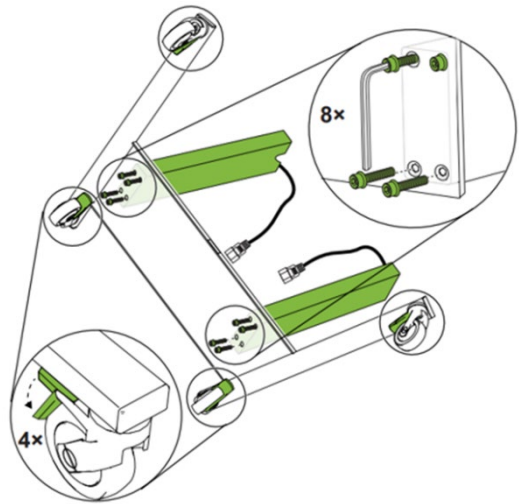

11. Return the floor stand to its upright position

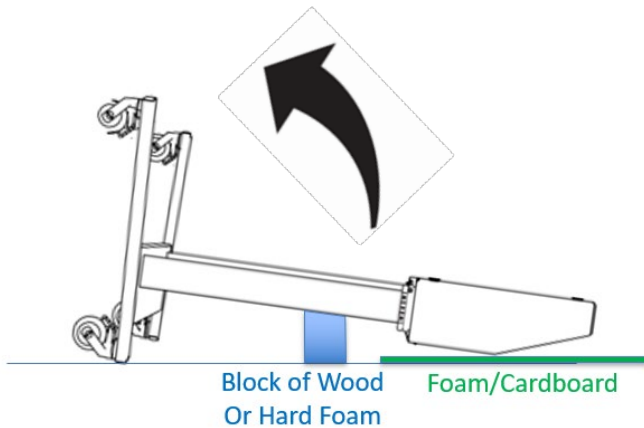

⚠ Important: Securely engage the wheel locks before positioning the stand upright

12. Mount display

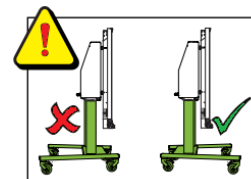
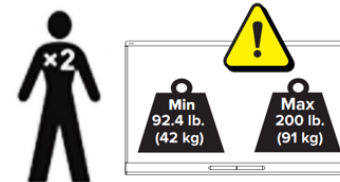
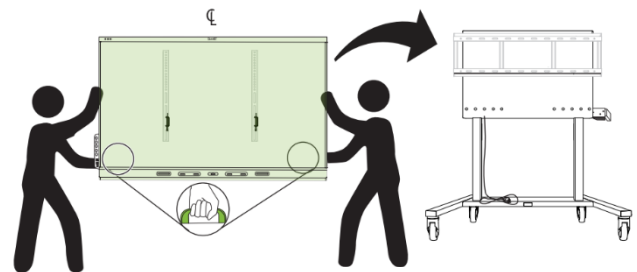

Important: Position the panel along the longer side of the wheelbase to avoid tipping and potential injuries.

SMART electric height-adjustable mobile stand wheelbase replacement

FSE-410 and FSE-400

13. Secure display locks

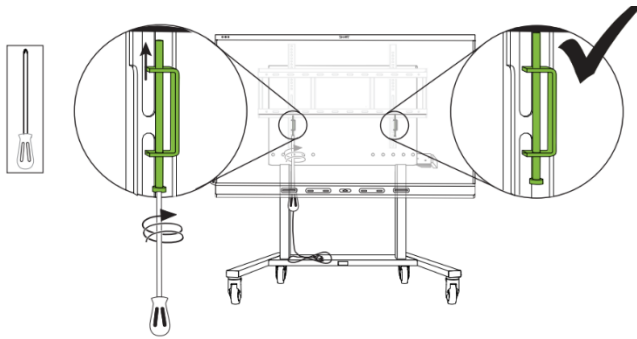

Secure the display to the wall plate by tightening the locking screws with a Phillips No. 2 screw driver until the screws contact the wall plate.

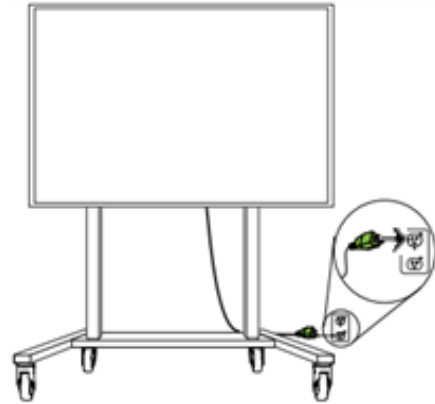

14. Plug & power ON the display and floor stand



15. Perform final checks

After stand assembly, calibrate before use.



Press the , , and  buttons in sequence

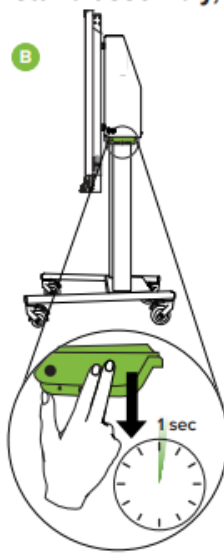

Ensure the stand is at the lowest position.

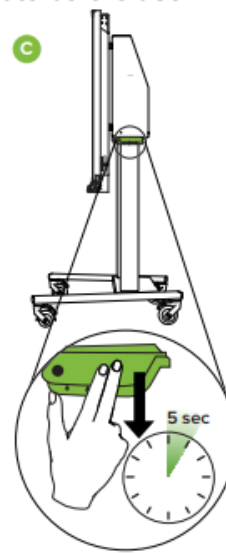

Press and hold the control switch for 5 seconds.

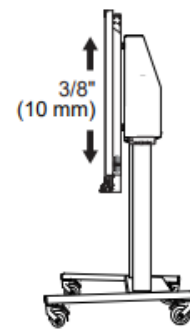





The stand moves up and down 3/8" (1 cm).

The stand is ready for use or has been reset.

Note: No need to calibrate FSE-400

SMART electric height-adjustable mobile stand wheelbase replacement

FSE-410 and FSE-400

Swapping the replacement wheelbase endcaps Note: Remove endcap(s) from the recalled wheelbase as needed.	
1. Use a flat screwdriver to gently push out the defective endcap without harming the thread or frame coating	2. Once the endcap is removed, cautiously insert an M10 bolt to extract by pulling out the nut
	
3. Reinsert the nut into the original wheelbase's endcap	4. Reinsert the assembly into the replacement wheelbase and begin mounting the castors
	

Video link: [Swapping the replacement wheelbase endcaps \(youtube.com\)](https://www.youtube.com/watch?v=...)

FSE-410/400 Asset information registration form

Visit our website for a downloadable version of this form:

[Important information for FSE-400 and FSE-410 models - SMART electric height-adjustable mobile stand \(smarttech.com\)](https://www.smarttech.com)



Verify that the batch number of the current wheelbase is included in the provided list (Batch: 2023034300005, 2023050300003, 2023050400000, 2023054500003, 2023066100000, 2023071900008 and 2023080700002) before proceeding with the replacement. If not, locate the defective wheelbase elsewhere and proceed with the replacement as necessary.

No.	(1) FSE-410/400 SN	(2) Current wheel-base Batch Number	(3) New wheel-base Batch Number	Remarks
1				

SMART electric height-adjustable mobile stand wheelbase replacement

FSE-410 and FSE-400

2				
3				
4				
5				
6				
7				
8				
9				
10				
11				
12				
13				
14				
15				
16				
17				
18				
19				
20				
21				
22				
23				
24				
25				
26				
27				
28				
29				
30				
31				
32				