



## Specifications

# SMART electric height-adjustable mobile stand

Model FSE-420

## Overview

Designed for the current line of SMART Board® interactive enterprise displays in North America, the SMART electric height-adjustable mobile stand features 26" (66 cm) of powered height adjustment. Safety features include a safety stop mechanism that reverses direction briefly if an obstruction is encountered. With its wide footprint and sturdy steel frame, the stand supports displays up to 86" (218 cm) diagonal that weigh up to 200 lb. (91 kg). The stand supports a maximum weight of 228 lb. (103 kg) with a display and accessories. You can easily roll the stand across smooth floors and secure it in place with the industrial grade 4" locking casters. The stand has a UL-certified drive system, is certified to UL 962 for Usage Area IA, and complies with Americans with Disabilities Act (ADA) standards. It also includes VESA mounting points for easy installation of the display and peripherals, a locking storage cabinet, and a surge-protected power bar.



See [smarttech.com](https://smarttech.com) for more information about this product.

## Dimensions and weights<sup>1</sup>

### Dimensions

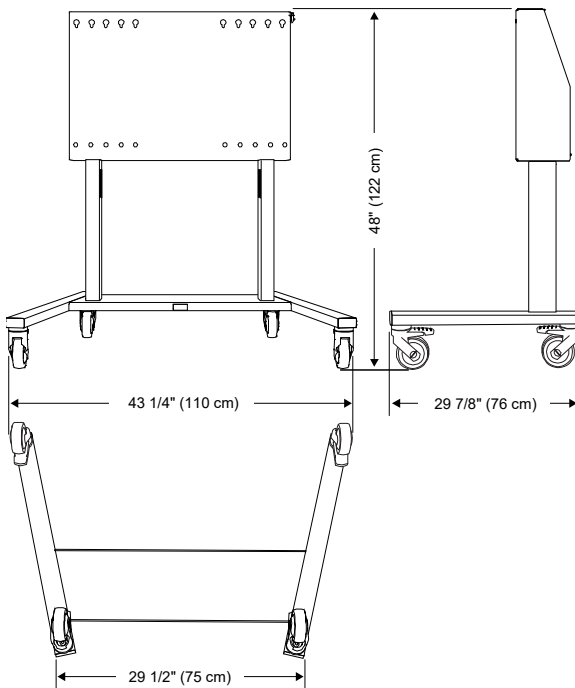

### Weight

106 lb. (48 kg)

### Shipping dimensions

45 2/8" × 32 5/8" × 7 3/8"

(115 cm × 83 cm × 19 cm)

### Shipping weight

115 lb. (52.5 kg)

### Storage cabinet dimensions

29 1/2" × 19 5/8" × 7 1/8"

(75 cm × 50 cm × 18.1 cm)

<sup>1</sup>All dimensions ± 1/8" (0.3 cm). All weights ± 2 lb. (0.9 kg).

## SMART electric height-adjustable mobile stand – Model FSE-420

### Specifications

## Hardware

Mobile stand color	Black
Supported SMART Board displays <sup>2</sup>	SMART Board GX series SMART Board MX and MX Pro series SMART Board QX Pro series SMART Board 6000 and 6000 Pro series SMART Board 6000S and 6000S Pro series SMART Board 7000 and 7000 Pro series SMART Board 7000R and 7000R Pro series SMART Board 2000 series
Maximum display size	Supports displays up to 86" (218 cm) diagonal and 80" (203 cm) wide
Maximum display weight	200 lb. (91 kg)
Maximum total weight (display and accessories)	228 lb. (103 kg)
<b>Height adjustment</b>	
Range	26" (66 cm)
Maximum extended height	74" (188 cm)
Minimum extended height	48" (122 cm)
<b>Components</b>	
Wheels	4" industrial-grade locking casters
Mounting	VESA® mounting pattern: 300 mm × 400 mm - M8, 500 mm × 400 mm - M8, 600 mm × 400 mm - M8, 700 mm × 400 mm - M8, 400 mm × 200 mm - M8  Displays with the following VESA mounting patterns require the use of the included WM-SBID-200 wall mount: 800 mm × 200 mm - M8, 800 mm × 400 mm - M8, 800 mm × 600 mm - M8 (see the <i>Addendum for SMART electric height-adjustable stands</i> , <a href="http://smarttech.com/kb/171893">smarttech.com/kb/171893</a> )

## Storage and operating requirements

### Power consumption

Supply voltage	100V–240V AC, 50 –60 Hz
----------------	-------------------------

<sup>2</sup>Some models require the included wall mount to install on a mobile stand. Refer to the model's documentation for details.

## SMART electric height-adjustable mobile stand – Model FSE-420

### Specifications

Nominal voltage	110V AC, 220V AC
	<b>Important</b> The supplied power bar can only be used with 120V input.
<b>Power consumption</b>	
Raising a display (maximum load)	300 W
Standby mode	0.1 W
Duty cycle	10% (2 minutes of operation fully loaded, 18 minutes of rest)
<b>Operating temperature</b>	50–104°F (10–40°C)
<b>Storage temperature</b>	14–158°F (-10–70°C)
<b>Humidity</b>	85% non-condensing

### Certification and compliance

<b>Regulatory certification</b>	FCC, ISED, UL Listed – U.S. and Canada UL 962 – Usage Area IA
<b>Other</b>	ADA
<b>Environmental compliance</b>	
U.S.	CONEG Packaging, California proposition 65

### Purchasing information

<b>Order numbers</b>	
FSE-420	SMART electric height-adjustable mobile stand
FSE-400-HL	Handles 8" x 6" x 4" (20.3 cm x 15.2 cm x 10.2 cm) 1 lb. 8 oz. (0.7 kg)
FSE-420-CH	Cable hook 8" x 6" x 4" (20.3 cm x 15.2 cm x 10.2 cm) 1 lb. (0.5 kg)
FSE-420-LS	Laptop shelf
<b>Optional accessories</b>	See <a href="https://www.smarttech.com/accessories">smarttech.com/accessories</a>
<b>Warranty</b>	Five-year limited equipment warranty

[smarttech.com/support](https://www.smarttech.com/support)  
[smarttech.com/contactsupport](https://www.smarttech.com/contactsupport)

© 2022–2023 SMART Technologies ULC. All rights reserved. SMART Board, smarttech, the SMART logo and all SMART taglines are trademarks or registered trademarks of SMART Technologies ULC in the U.S. and/or other countries. All third-party product and company names may be trademarks of their respective owners. This product and/or use thereof is covered by one or more of the following U.S. patents: [www.smarttech.com/patents](https://www.smarttech.com/patents). Contents are subject to change without notice. June 12, 2023.