

# SMART MultiStylus with Tool Explorer (V2) technology



## Overview

The SMART MultiStylus accessory kit is a multi-functional stylus with a docking station that unlocks new capabilities on SMART Board® interactive displays with iQ 4, whether users are at the screen or moving freely around the room. With pen and air mouse modes, customizable buttons, and integrated Tool Explorer™ (V2) support for cubes and stamps, it enables more interactive teaching, collaboration, and lesson presentation work flows.

## Features

<b>Supported functionality</b>	Pen mode Air-mouse mode
<b>Buttons</b>	<ul style="list-style-type: none"> <li>• Programmable LED</li> <li>• Programmable Up/Down</li> <li>• Eraser</li> </ul>
<b>Stylus tip</b>	4096 levels of pressure
<b>Eraser</b>	Pressure-activated

## Interactive experience

<b>Pen mode functions</b>	Color selection   Highlighter   Pressure-sensitive inking   Pressure erase   Arrow up   Arrow down   Open whiteboard   Open browser   Freeze screen   Open digital assistant
<b>Air-mouse mode functions</b>	Cursor   Highlighter   Laser pointer   Mouse click left   Mouse click right   Arrow up   Arrow down   ESC key   Screen shade   Freeze screen   Screen shot   Open digital assistant   Open browser   Magnify text
<b>Tool Explorer™ function</b>	Optional cubes and stamps (V2)

## Connectors and mounting

<b>Docking station connector</b>	USB 2.0 Type-C input
----------------------------------	----------------------

<b>Docking station mount</b>	Magnetic, mounted on the display's frame
------------------------------	--

<b>Stylus mount</b>	Magnetic, mounted on the docking station
---------------------	--

## Power MultiStylus

<b>Power source</b>	Ultra-capacitor
<b>Auto-on</b>	Motion-activated
<b>Usage time</b>	10 hours (mode dependent)
<b>Standby time</b>	168 hours (in sleep mode; activates after 10 minutes of inactivity)
<b>Charge time</b>	Quick charge: 1 minute for up to 60 minutes of usage time Full charge: 6 minutes
<b>Charge method</b>	Wireless charging using the docking station

## Docking station

<b>Power source</b>	5V DC
<b>Power consumption</b>	<4.5W

## Storage and operating requirements

<b>Operating temperature</b>	41–95°F (5–35°C)
<b>Storage temperature</b>	–40–76°F (–40–60°C)
<b>Humidity</b>	5–80% relative humidity, non-condensing

## SMART MultiStylus with Tool Explorer (V2) technology

Included components	Qty
SMART MultiStylus	1
SMART Docking Station with Tool Explorer (V2) technology	1
USB 2.0 Type C to Type A, 3 m	1
Hardware set (1 screwdriver, 2 screws)	1
Illustrated installation instructions	1

### Connectivity

<b>Wired</b>	USB-C to USB-A
<b>Wireless operating range</b>	>98' (30 m) (in an open area) <sup>1</sup>

### Tool integration

<b>Software</b>	iQ 4.7.2 or later SMART Product Drivers and Ink® SMART Notebook® 25 or later
<b>Operating systems</b>	Windows 11 MacOS 26
<b>Compatible displays</b>	SMART Board MX (V5) SMART Board MX (V5) Plus SMART Board QX (V2) Pro SMART Board RX
<b>Accessories</b>	Tool Explorer (V2) stamps and cubes

### Certification and compliance

<b>Regulatory models</b>	SMART MultiStylus: PQR-3   SMART Docking station: CBQR-3
<b>US / Canada</b>	FCC   ISED
<b>EU / EEA / EFTA / UK</b>	CE   UKCA
<b>Australia / New Zealand</b>	RCM

### Purchasing information

#### Order numbers

<b>SMS-TE-IQ4</b>	SMART MultiStylus with Tool Explorer (V2) technology, Accessory Kit, for displays with embedded iQ 4
-------------------	--

#### Optional accessories

<b>TE-4CUBE-V2</b>	Tool Explorer (V2) cubes
<b>TE-4STAMP-V2</b>	Tool Explorer (V2) stamps

### SMART Warranty

Terms and conditions and warranty upgrade options vary by region. Visit [smarttech.com/warranty](https://smarttech.com/warranty) or contact your reseller for information.

<sup>1</sup>Range may vary depending on the environment and obstructions.

## Installation, dimensions, and weights

### Notes

- All dimensions  $\pm 0.3$  cm. All weights  $\pm 5$  g.

## SMART MultiStylus

### Dimensions

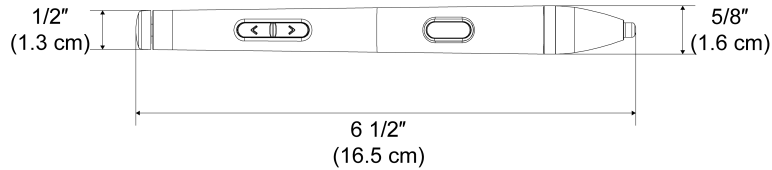

### Weight

1.1 oz (31 g)

### Shipping dimensions

8 1/4 x 3 5/8 x 1" (21 x 9.2 x 2.5 cm)

### Shipping weight

3.2 oz (90 g)

## SMART Docking Station

### Dimensions

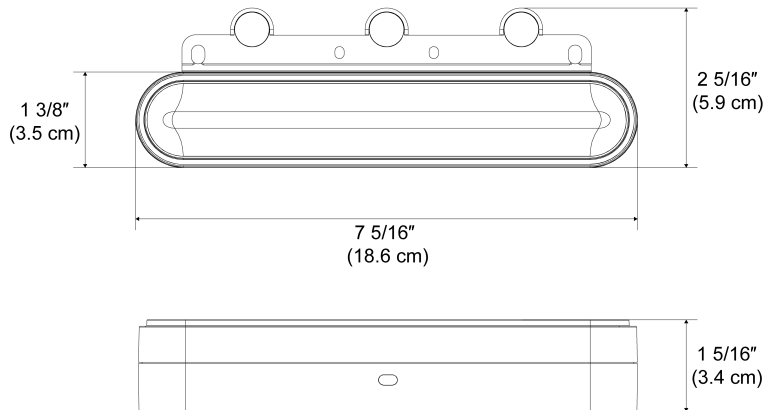

### Weight

6.2 oz (175 g)

### Shipping dimensions

9 7/8 x 5 1/2 x 3 1/4" (25 x 14 x 8.3 cm)

### Shipping weight

11.5 oz (325 g)

[smarttech.com](http://smarttech.com)  
[smarttech.com/contact](http://smarttech.com/contact)

© 2026 SMART Technologies ULC. All rights reserved. SMART Board, smarttech, the SMART logo and all SMART taglines are trademarks or registered trademarks of SMART Technologies ULC in the U.S. and/or other countries. All third-party product and company names may be trademarks of their respective owners. This product and/or use thereof is covered by one or more of the following U.S. patents: [www.smarttech.com/patents](http://www.smarttech.com/patents). Models and specifications may vary by region. Please contact your local representative for details. Contents are subject to change without notice. April 29, 2026.